

Flowscale MARELEC M1-F

Accuracy

Fast weighing

Robust
construction



MARELEC offers the best equipment for flow weighing. These systems are able to weigh accurately a flow of products, e.g. pelagic fish or ice, over a certain period of time. This eliminates the need for collecting raw material in trays or tubs for weighing and gives a continuous raw material throughput.

For this purpose we have developed the MARELEC M1-F100, with a capacity of 100 ton/hour. The machine can be used on shore or at sea (optional).

Every piece of raw material is weighed with the conveyor belt running and weighing results are added up to a total.

The machines are developed to be used in the most severe marine environment, and in this way accurate and fast weighing is always assured.



MARELEC Z2
Indicator



FUNCTIONS*

Measurement : M1-F100 : 0 - 40 kgf

Measurement of total product weight over a certain weighing period

Precision : 1% of total depending on the product

Conveyor speed : M1-F : 0,3 - 0,5 m/s

Electronic digital indicator

Memory with total weight during the weighing period

Output contact at programmable value (optional)

OIML R50 certification (pending)

EXECUTION

Platform and machine in stainless steel type AISI 304

Load cell hermetically protected IP68

Security against mechanical overload integrated

Selection keyboard in stainless steel IP67 with integrated electronics

Conveyor in grid polyethylene

FEATURES

Construction : Stainless steel AISI 304.
All vulnerable parts are built-in hermetically.

Conveyor belt : Polyethylene modular belt

Belt width : M1-F100 : 800 mm

Power supply : Single phase 230VAC 50Hz 800W

Capacity : M1-F100 : 100 ton/hour at 0,5 m/s

Protection : Protected against mechanical overload

Load cells hermetically protected IP68

User-friendly : Easy to use, easy to clean

DIMENSIONS

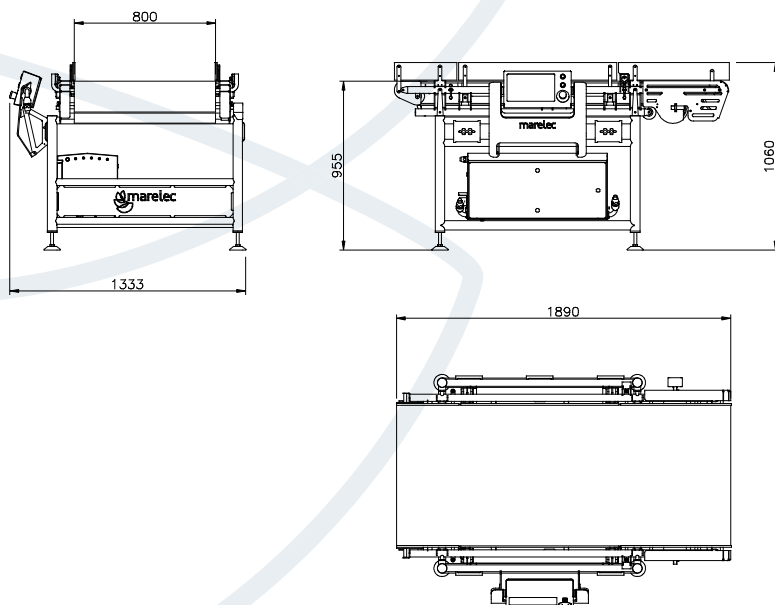

* Specifications are subject to modifications

MARELEC Food Technologies

Redanweg 15
8620 Nieuwpoort
Belgium

T +32 58 222 111

F +32 58 239 280

sales@marelec.com

