



---

# MARELEC IV

## Intelligent Vision

---



# Overview

---

The MARELEC IV cam sorter is a latest generation line scan heavy duty camera system with custom lighting and MARELEC artificial intelligence software for recognition of fish species or fish & meat quality (e.g. spots, meat and fat content).

The products are guided one by one over a moving belt. The MARELEC IV automatically detects the product, generates its features, stores the information and controls the optional control unit for further processing of the product.

## // FEATURES & APPLICATIONS

- Species, quality and feature detection
- Size detection
- Artificial Intelligence program
- Accuracy: from + 90%
- Traceability
- Maximum speed: 3 pieces/sec at 1500 mm/belt speed
- Smallest footprint, can be mounted on an existing belt
- Output of all data to PC computer or control unit
- Heavy duty IP68
- Stainless steel AISI304
- Dimensions: 749 x 504 x 426 mm (l x b x h)
- Power supply: 220 VAC/500W

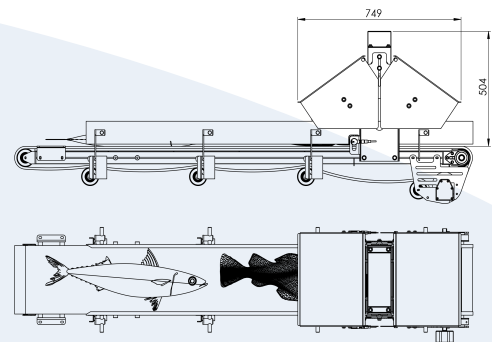

## // DELIVERY EXTENDS

- One MARELEC IV camera unit with integrated lighting
- One touchscreen MARELEC Z4 computer
- One MATRIX IV pc software for logging and control
- Optional: control box for connection to MARELEC Grader belt or other
- Not included: mounting belt, power supply, optional windows 10 PC computer

